



Hero Medical Premium
Comfy Lite Wheelchair
User Manual

Contents

Section	Title	Page
1	Introduction	2
2	Safety & Precautions	3
3	Transporting in the Wheelchair	4
4	Labelling Information	7
5	Features	9
6	Specifications	9
7	Instructions for Use	10
8	Product Care & Maintenance	16
9	Warranty	16
10	Recycle & Disposal	17

No part of this user manual may be copied, distributed, reproduced, duplicated, scanned or stored whether in whole or part in any form or by any means without the expressed written consent from Independent Living Specialists Pty Ltd. Independent Living Specialists does not accept responsibility for any changes, errors or omissions. All information is subject to change without prior notice and products may vary from that of the actual images depicted.

1 Introduction

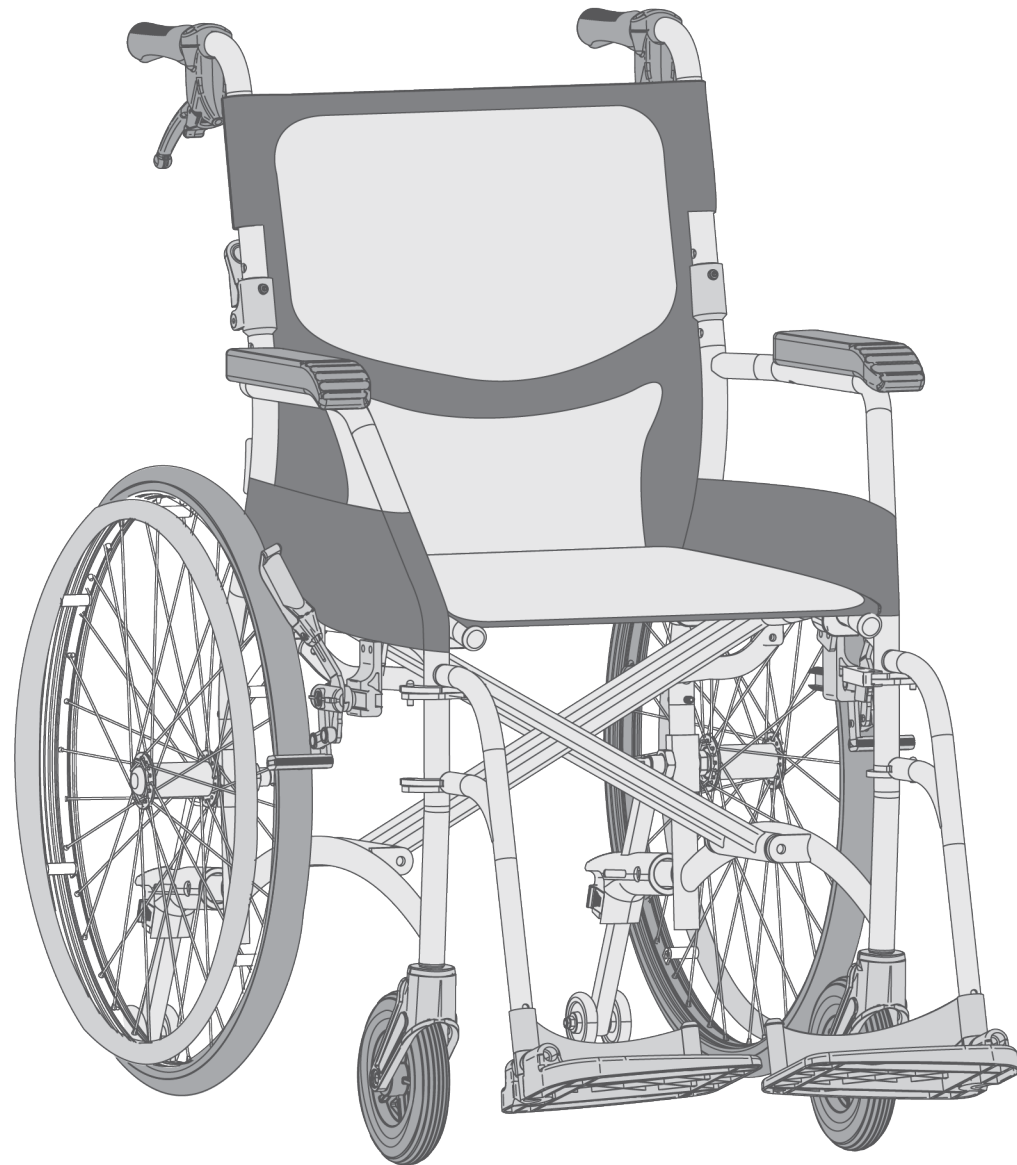

- S309156 Wheelchair – Hero Medical Premium Comfy Lite 16” Self-Propelled Matte Black 135kg
- S309152 Wheelchair – Hero Medical Premium Comfy Lite 16” Transit Matte Black 135kg
- S309157 Wheelchair – Hero Medical Premium Comfy Lite 18” Self-Propelled Matte Black 135kg
- S309153 Wheelchair – Hero Medical Premium Comfy Lite 18” Transit Matte Black 135kg
- S309158 Wheelchair – Hero Medical Premium Comfy Lite 19” Self-Propelled Matte Black 135kg
- S309154 Wheelchair – Hero Medical Premium Comfy Lite 19” Transit Matte Black 135kg

Safety & Precautions 2

Stability – The Premium Comfy Lite Wheelchair range has been designed with the user’s comfort and safety in mind. Users must be seated securely in the wheelchair when using the equipment. Avoid sudden movements, e.g. jolting or pushing the wheelchair suddenly, which may cause the user to fall forward

Uneven Terrain – When using this wheelchair over uneven terrain or surfaces, this could increase the risk of causing the wheelchair to tip over, particularly when going uphill or downhill. When riding over an incline, the user should be leaning forward. When riding over a decline, the user should be leaning back.

Weight Capacity – The recommended safe working load is 135kg and this must never be exceeded. If the maximum load is exceeded, this can lead to damaging the wheelchair and increase risk of serious injury to the user and others.

Handle With Care / Pinching Hazards – The wheelchair has areas which may cause pinching hazards for fingers and limbs during assembly and disassembly. Areas that have been identified as trapping or pinching hazards are:

- a. The footplates, when raising and lowering them.
- b. The height adjustable anti tipper, when adjusting the height.
- c. The seat frame when folding and unfolding the wheelchair.

Safe Handling of the Wheelchair – To avoid pinching hazards, the wheelchair has safe grip areas. These are:

- a. The two handle grips are located at the back of the wheelchair for safely moving the wheelchair.
- b. Padded armrest and legrest with foot strap is available on each side to ensure user safety while in use.

Exposure to Weather – If the wheelchair is exposed to hot or cold temperatures for a long period of time, then the wheelchair may become very hot or very cold which may increase the risk of burns to the user, as well as damage to the wheelchair itself.

Safety Check Before Use – It is highly recommended for the safety of the user the below checks are performed before use every time:

- a. Check the brakes
- b. Check the castors for wear and tear
- c. Check whether or not all the removable parts are securely fastened (eg: legrest hanger, foot plates, castors)

3 Transporting in the Wheelchair

This section relates exclusively to wheelchairs that have received crash test certification in accordance with ISO 7176. S309152 and S309153 have both been granted crash test certification under ISO 7176.

This wheelchair is designed to be secured facing forward when used as a seat in a motor vehicle and it complies with the requirements of ISO 7176-19:2008. The occupied wheelchair needs to be transported forward facing only.

Following points need to be considered before using the wheelchair to transport the user in a motor vehicle.

- The wheelchair has been designed to be used as a seat in a motor vehicle and complies with the requirements of ISO 7176-19:2008. It is highly recommended that the user is transferred to the vehicle seat and utilises the vehicle's restraint system where possible.
- The vehicle used must be suitable to transport a user occupied wheelchair. It should have sufficient space around the wheelchair to be able to safely and securely attach and release the occupant tie down restraint and safety belts.
- Unoccupied wheelchair should be stored in the trunk or safely secured in the vehicle during travel.
- The occupied wheelchair must be located in a forward facing position and secured by the wheelchair tie down and occupant restraint straps (WTORS tie downs meeting the requirements of ISO 10542 or SAE J2249) in accordance with the WTORS manufacturer's instructions.
- The wheelchair should be secured by a Tie Down Restraint system, with non-adjustable front straps and adjustable rear straps, which typically use Carabiner clips/S hooks and tongue and buckle fittings. These restraints generally comprise of 4 individual straps that are attached to each corner of the wheelchair.
- Any alteration and substitution should not be made to the wheelchair securement points or to structural and frame parts or components without consulting the manufacturer.
- A head rest or head support suitable for transportation must be fitted and suitably positioned at all times during transportation.

Occupant Belt Restraint System

This wheelchair is designed to use vehicle anchored lap and shoulder belt restraints. The belt restraint should make good contact with the occupant's body and not be held away by wheelchair components.

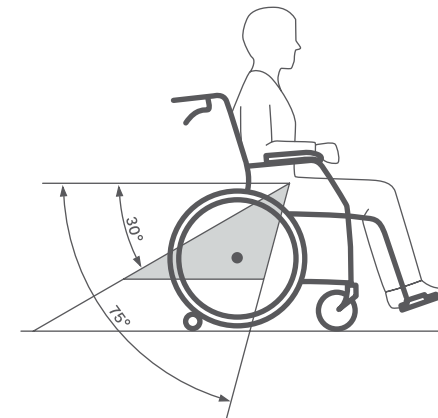

Figure A

The pelvic-belt restraint should be worn across the front of the pelvis, so that the angle of the pelvic-belt restraint is within the preferred zone 30° to 75° to the horizontal, similar to that of Figure A. A steeper (greater) angle within the preferred zone is desirable.

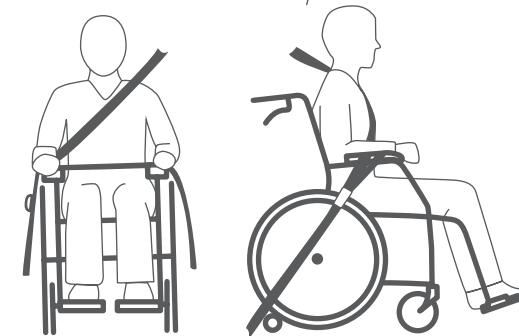

Figure B

Belt restraints must not be held away from the body by wheelchair components such as armrests or wheels.

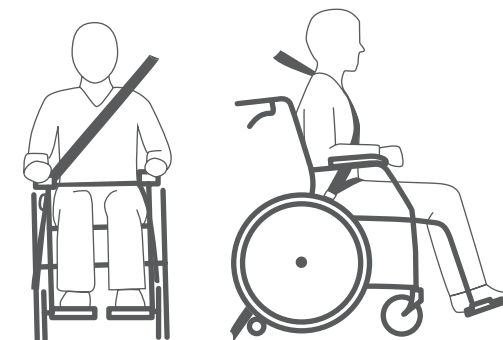

Figure C

Belt restraints should make full contact with the shoulder, chest, and pelvis and pelvic belts should be positioned low on the pelvis near the thigh abdominal junction.

The belt restraints should be adjusted as tightly as possible, consistent with user comfort and belt webbing should not be twisted when in use.

To reduce the potential risk of injury to the user, wheelchair mounted accessories not specifically designed or tested as per crash safety should be removed and secured separately in the vehicle.

Labelling Information

4

Tie Down Points On The Wheelchair

The wheelchair has 4 tie-down anchorage points. Two are located above the front castor and two at the rear. Tie down labelling can be found on frame for suitable positioning.

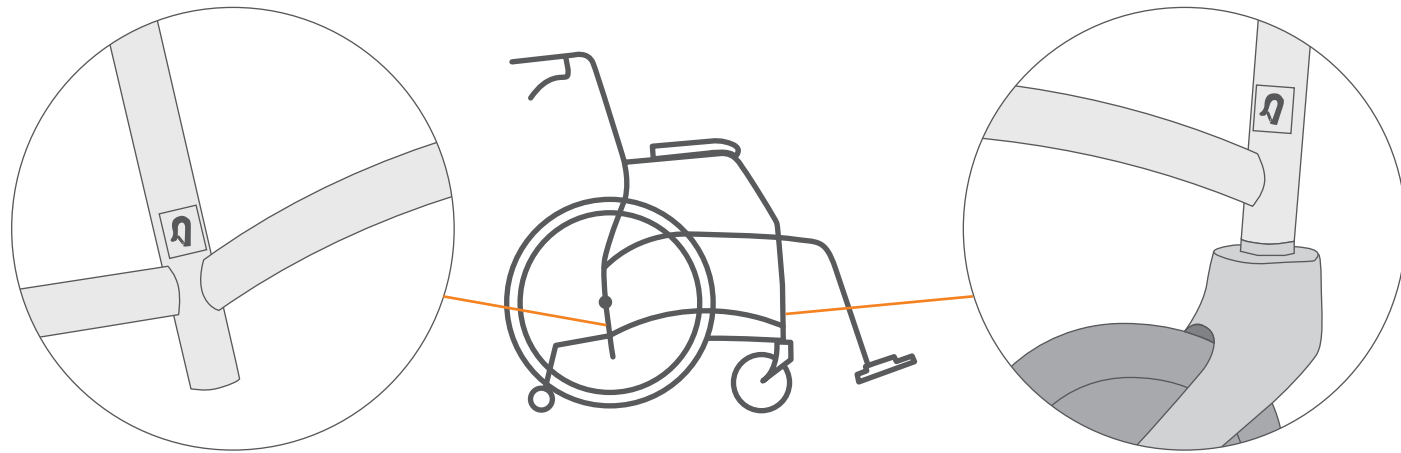

a. Product Label

The wheelchair has a product label which can be found above the right front castor. The product label has the following information:

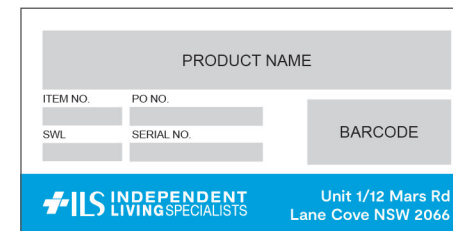

- Name and address of the company
- Name and code for the product
- Safe Working Load (SWL)
- Serial number of the product (which includes the date of manufacture and the batch serial number)

b. Anchorage Label or Tie Down Point Label

This label relates exclusively to wheelchairs that have passed Crash Testing and are certified in accordance with ISO 7176.

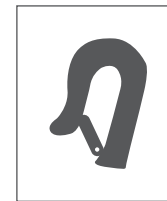

Models Certified:

- S309152 - Wheelchair - Hero Medical Premium Comfy Lite 16" Transit Matte Black 135kg
- S309153 - Wheelchair - Hero Medical Premium Comfy Lite 18" Transit Matte Black 135kg

c. Usage Label

This label is applicable to the wheelchairs that do not have crash test certification in accordance with ISO 7176.

Hero Medical Premium Comfy Lite Wheelchair

This wheelchair is not intended for use as a motor vehicle seat. This wheelchair does not have tie-down anchorage points (Not AS/NZS 3696.19 Compliant).

5 Features

- ▶ Soft seat and backrest for comfort
- ▶ Ultra-light weight
- ▶ Powder coated aluminum frame to prevent corrosion and maximize lifespan
- ▶ Seat belt included
- ▶ Height adjustable anti-tippers

6 Specifications

Specifications	S309152	S309156	S309153	S309157	S309154	S309158
Type	Transit	Self-Propelled	Transit	Self-Propelled	Transit	Self-Propelled
Seat width	40cm	40cm	45cm	45cm	47.5cm	47.5cm
Seat depth	42cm	42cm	42cm	42cm	42cm	42cm
Seat height (from floor)	44cm	45cm	44cm	45cm	44cm	45cm
Overall height	93cm	92.5cm	93cm	92.5cm	93cm	92.5cm
Backrest height (from seat)	43.5cm	42.5cm	43.5cm	42.5cm	43.5cm	42.5cm
Front castors	6"	6"	6"	6"	6"	6"
Rear wheels	13"	22"	13"	22"	13"	22"
Net weight	9.7kg	11.7kg	9.9kg	11.9kg	10.1kg	12.1kg
Safe working load (SWL)	135kg	135kg	135kg	135kg	135kg	135kg
TGA	388720	388720	388720	388720	388720	388720
Compliance	AS/NZS 3695.1:2011 ISO 7176	AS/NZS 3695.1:2011	AS/NZS 3695.1:2011 ISO 7176	AS/NZS 3695.1:2011	AS/NZS 3695.1:2011	AS/NZS 3695.1:2011

Instructions for Use 7

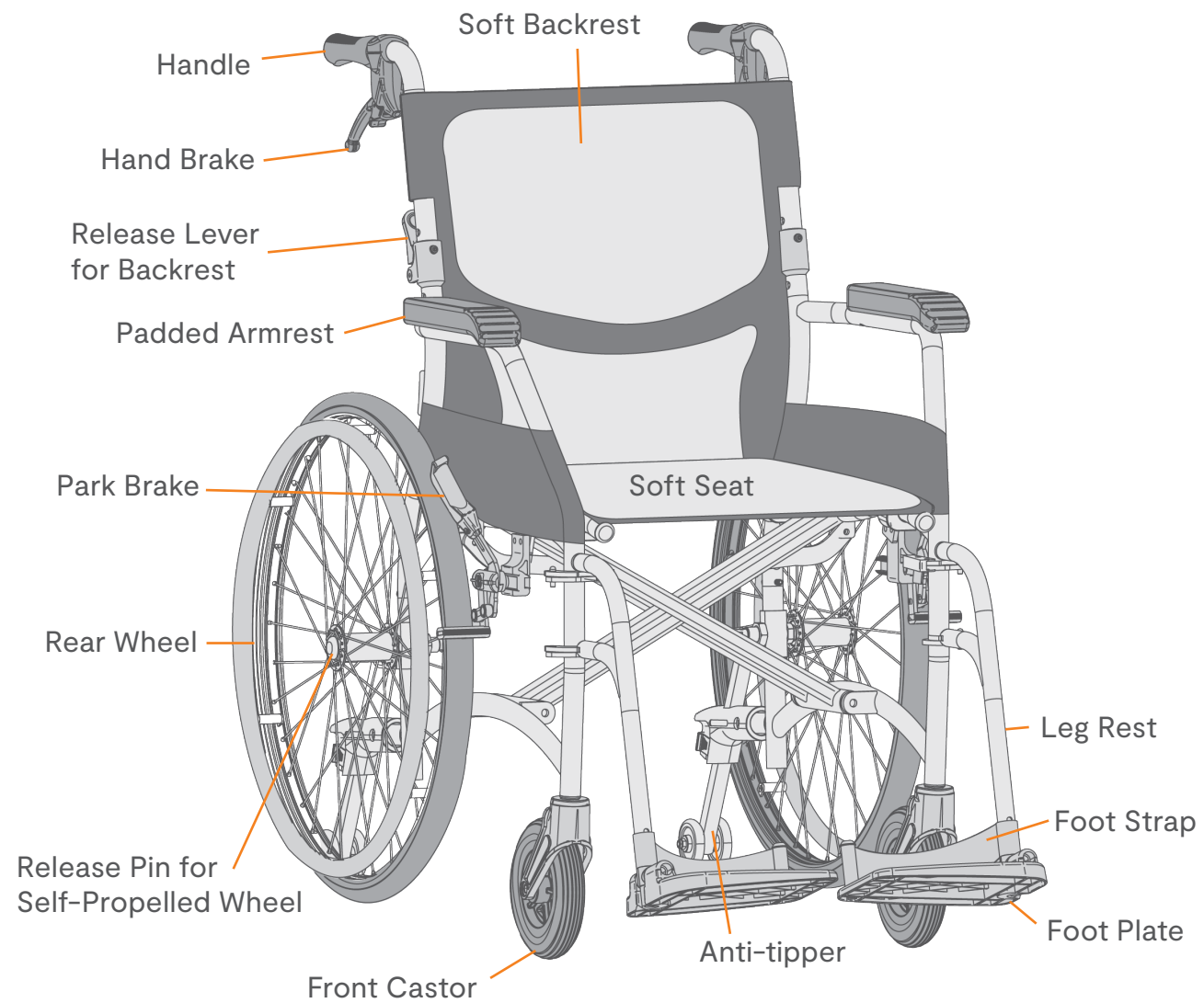

Hand Brakes or Attendant Brakes

The wheelchair comes with attendant handbrakes to provide better control and safety.

- To apply the hand brake when in motion, pull the brake lever towards the grip handle and vice versa to release.
- To park, pull the brake lever towards the grip handle and press the locking pin downwards. To release the hand brakes, pull the brake lever towards the handle.
- There is a tension adjustment nut at the end of the brake cable where it inserts into the frame above the rear wheel. This adjustment nut can be used to tighten the cable, or loosen if brakes are too tight and don't allow the rear wheels to roll freely.

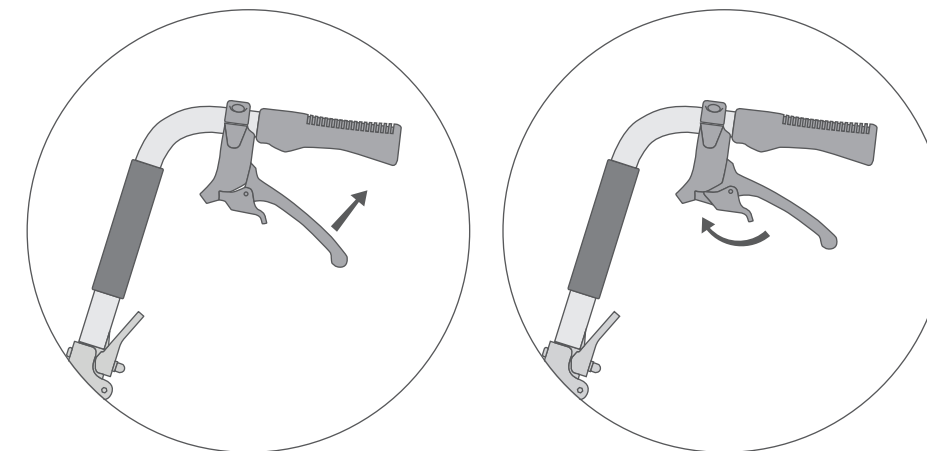

User Locking Park Brake

To apply the park brake, push the brake lever forward until it's locked. To release the park brake, pull the brake lever until it's unlocked.

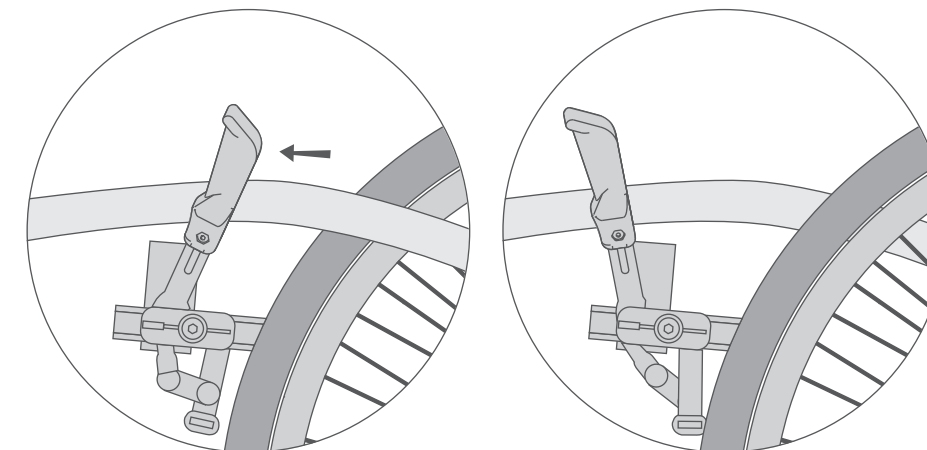

Unfolding the Backrest

Lift up both the handles towards the frame until you hear a click locking it in place.

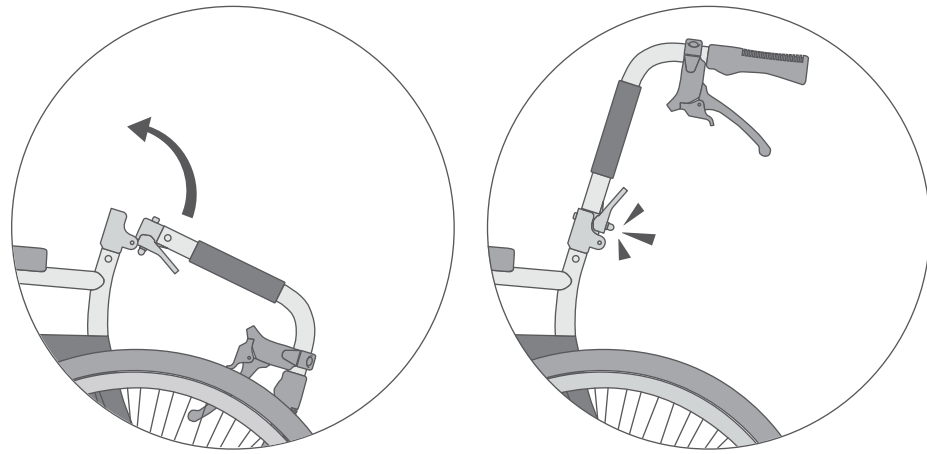

Unfolding the Wheelchair

Grabbing both handles, push outwards until the frame is half open. Place both hands on the side of the seat and push downwards to fully expand the wheelchair.

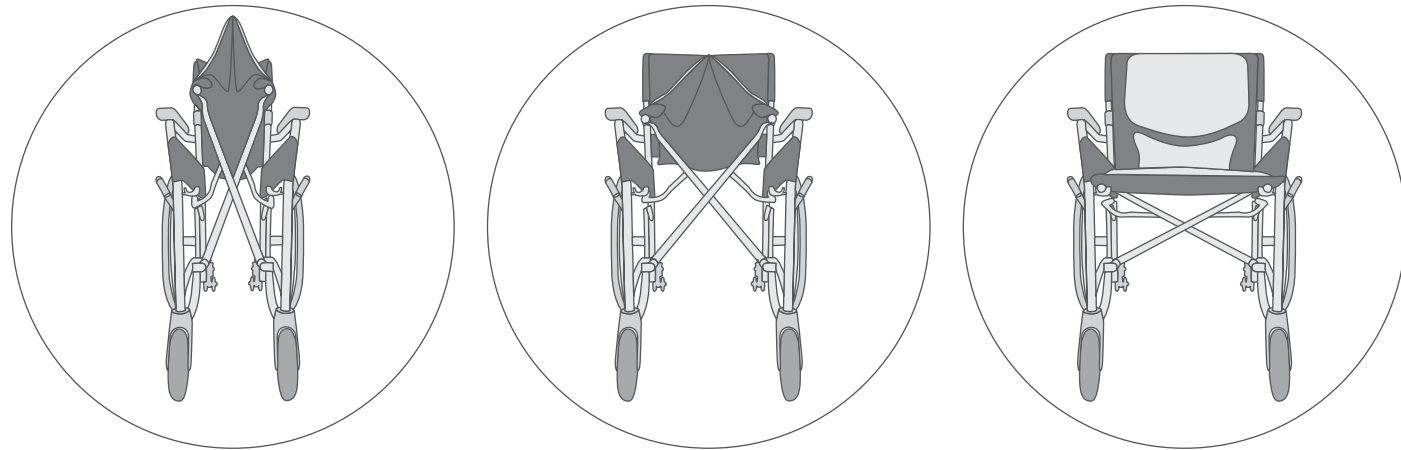

Attaching the Leg Rests

Position the leg rest parallel to the side of the frame, with the footrest facing the back wheels and the silver clip facing away from the frame. Now place the leg rests securely on the 2 silver pins located above the front castors. Then swivel the leg rest forward until you hear the silver clip click, locking it against the frame. Push both footplates down until they are parallel to the ground.

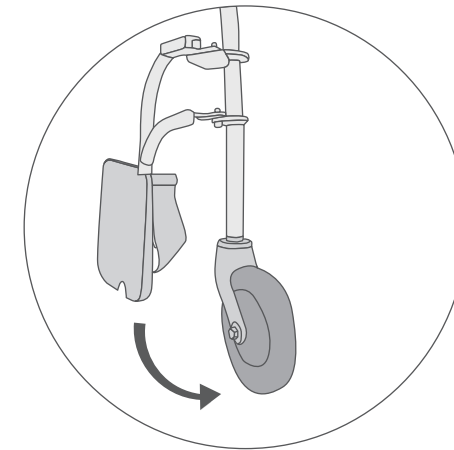

Attaching the Seat and Backrest Cushion

Fasten the upper part of the backrest cushion to the rear of the backrest using Velcro, and affix the lower section of the cushion to the front of the backrest. Attach the seat cushion onto the seat, making sure to secure the front of the cushion beneath the seat. Additionally, the seat and backrest needs to be fastened using the velcro strips provided.

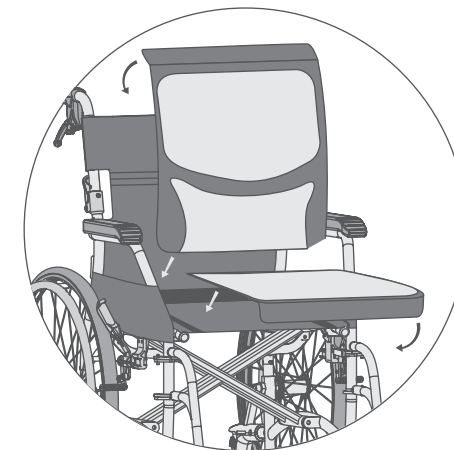

Adjusting Height of the Footrest

Loosen the screw on the footplate. Move the footplate to the desired height. Tighten and secure the screw.

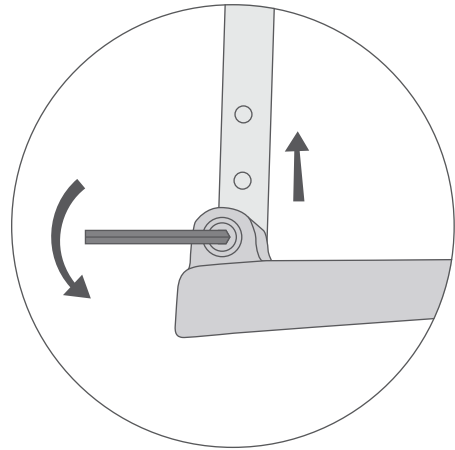

Adjusting the Height of the Anti-tippers

Pull the red clip on the anti-tip to release the lock. Move the anti-tip to the desired height and release the red clip to lock it.

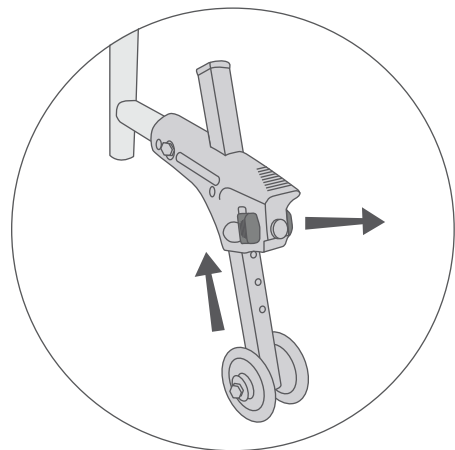

Folding the Wheelchair

Remove the Leg Rests: Pull the footplates up to fold it. Undo the silver clip by pulling the clip towards the opposite leg rest and remove the leg rest by lifting up from the pins.

Folding the Wheelchair: Grab the front and back of the seat and lift upwards to collapse the wheelchair halfway. Then gently push both the arms inwards to fully fold the wheelchair.

Folding the Backrest: Pull the two black clips located behind each armrest to unlock from the frame. Push down both the handles towards the back wheels to fold.

Removing the Wheel from the Self-Propelled Wheelchair

Press the release pin on the self-propelled wheel to release and remove the wheel.

Product Care & Maintenance 8

The castors, seat and back rest needs to be checked regularly for wear and tear. Recommended maintenance for these is every 3 months. Replace these parts when there is visible wear and tear.

The brake function needs to be tested before every use of the wheelchair. The brake can be easily tightened or loosened as required. Please refer to the hand brake section for further details.

- If the wheelchair is exposed to water or moisture, always ensure the wheelchair is dried promptly to prevent corrosion of the frame. The wheelchair should be wiped down regularly using warm water or a mild detergent.
- All the replacement parts, as well as after-sales support and repair services are available through Hero Medical Dealers.

Warranty 9

The Hero Medical Premium Comfy Lite Wheelchair has a 12 months warranty from the date of purchase on structural integrity.

- During the warranty period any parts that have become defective due to faulty workmanship or material will be repaired or replaced without charge by a Hero Medical supplier/dealer.
- The warranty excludes castors, wheels, components and parts that are subject to reasonable wear and tear.
- The warranty excludes faults that have been identified as misuse or user error.
- Unauthorized changes or modifications will forfeit your warranty.
- If a defect or fault is discovered, the Hero Medical supplier/dealer from where the wheelchair was purchased should be contacted immediately.

10 Recycle & Disposal

The following information describes the materials used in the wheelchair. Recycling and disposal should always be done through an authorized agent for disposal.

- Frame: tubular aluminium frame
- Armrest: polyurethane armrest
- Seat, backrest and foot straps: fabric and nylon
- Castors and Handgrips: polyurethane
- Packaging: cardboard carton and plastic

Please follow the local government rules in regards to the proper disposal and recycling.

HERO 

Independent Living Specialists
Unit 1, 12 Mars Road
Lane Cove West NSW 2066
1300 008 267 | ilsau.com.au

©2025 ROYALE MEDICAL. INDEPENDENT LIVING SPECIALISTS

PDT025-0125