



**ALIVIO**

User Manual

## **Alivio Lift Recliner**

Picasso  
Leonardo  
Michelangelo  
Donatello  
Carrington  
Kahlo

# COMFORT & STYLE

**KCare**  
Healthcare Solutions

# Alivio Lift Recliner User Manual

Important Safety Instructions .....	2
Assembly: Cord & Transformer Connection .....	4
Assembly: Attaching the Back to the Base .....	5
Assembly: Attaching the Wings to the Back .....	6
Operation: Handsets .....	7
Maintenance: Installation of Back-Up Batteries .....	12
Maintenance: Lithium-Ion Battery Pack Back-Up System .....	13
Troubleshooting .....	14
Cleaning & Maintenance .....	15
Warranty .....	16

**NOTE:** When placing the furniture on non-carpeted flooring, K Care Healthcare Solutions recommend the use of floor protection such as an area rug or furniture pads. Area rugs and padding not included with purchase.

K Care Healthcare Solutions recommends K Care Fabric Armour (KP100) stain resistant treatment before use.

# Important Safety Instructions

## READ ALL INSTRUCTIONS BEFORE USING

**WARNING: To reduce the risk of burns, fire, electric shock, or injury to persons:**

DANGER: To reduce the risk of electric shock, always unplug this furnishing from the electrical outlet before cleaning.

Unplug from outlet before putting on or taking off parts.

Close supervision is necessary when used by (or near) children. Persons with a disability should be assessed before.

Use this furnishing only for its intended use (as described in these instructions). Do not use attachments not recommended by the manufacturer.

Never operate this furnishing if it has a damaged cord or plug, if it is not working properly, if it has been dropped/damaged, or dropped into water.

Keep the cord away from heated surfaces.

Never drop or insert any object into any opening.

Do not use outdoors, for household, indoor use only.

Do not operate where aerosol (spray) products are being used, or where oxygen is being administered.

To disconnect, turn all controls to the off position, then remove plug from outlet.

WARNING: Risk of injury - keep children away from extended foot support.

WARNING: Risk of injury and product damage - Do not sit on the extended foot support.

WARNING: Risk of injury to persons - do not use this furnishing to support video equipment, such as televisions or computer monitors.

When not in use, it is recommended the handset be stored securely in the pocket on the outside of the arm.

## SAVE THESE INSTRUCTIONS

### SERVICING OF DOUBLE-INSULATED PRODUCTS:

In a double-insulated product, two systems of insulation are provided instead of grounding. No grounding means is provided on a double-insulated product, nor is a means for grounding to be added to the product. Servicing a double-insulated product requires extreme care and knowledge of the system, and is to be done only by qualified service personnel. Replacement parts for a double-insulated product must be identical to the parts they replace.

# Important Safety Instructions

## READ ALL INSTRUCTIONS BEFORE USING

**WARNING: To reduce the risk of burns, fire, electric shock, or injury to persons:**

### Special Precautions for Li Ion Battery Backup

Lithium-ion batteries are the most widespread portable energy storage solution and have better power efficiency than other types of batteries. Whilst incidents are rare, they appear to be increasing and are serious when they occur. The batteries can overheat or explode if they are used, charged or disposed of incorrectly or if they are damaged, and fires caused by the batteries can be dangerous and difficult to extinguish.

The Lithium Battery pack that may be included with your chair has been sourced from reputable suppliers and includes battery management technology to reduce the risk of incident, however following the recommendations below will help ensure a long battery life and safe use of the product for many years to come.

If your product is equipped with a Li Ion battery pack please observe the following additional safety precautions:

The backup battery and integrated battery management system has been designed to be permanently connected

to the chair in case of power outage. We do not recommend removing the backup battery unless the chair will not be in use for an extended period.

**ALWAYS** use the charger supplied by the manufacturer

Regularly check the battery pack for damage. A battery pack that is overheating, damaged, swollen, leaking or emitting gas should be unplugged immediately.

**ALWAYS** keep the battery pack in cool dry places, away from sources of heat and out of direct sunlight.

**NEVER** dispose of Li Ion batteries in household waste.

**In case of Fire call 000 for assistance.**

**SAVE THESE INSTRUCTIONS**

# Assembly

## Cords & Transformer Connections

Once the box has been removed from around the chair, you'll notice the back is resting on top of the seat. There are a couple of items to remove from the seat portion of the chair first.

### Follow the steps below:

1. Remove the zip tie holding the plastic bag with the Power Transformer, hand handset and its cord on the left.
2. Remove the hand handset from the plastic bag and connect it to the female plug located in the right side pocket on the outside of the chair's arm.
3. Connect the Power Transformer to the plug coming from the chair.
4. Connect the Power Cord into the Power Transformer.
5. Connect the Power Cord into an electrical outlet, near where the chair will be positioned.

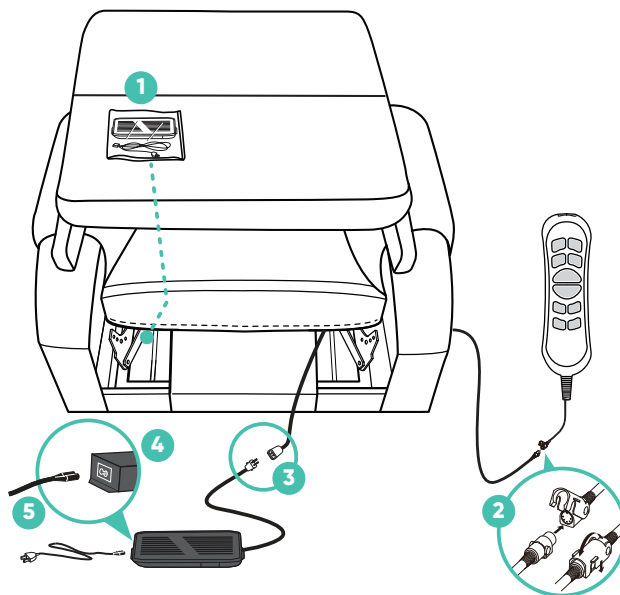

# Assembly

## Attaching the Back to the Base

**CAUTION:** please read all instructions carefully before starting assembly process. It is recommended to use two people when assembling and removing the back to and from the base of the furniture.

**Follow the steps below:**

1. Slide inside back receivers onto the steel mechanism posts in the base of the chair (1).
2. Press both sides of the back firmly into place until the back automatically locks into place. once fitted gently lift back up to ensure back has secured correctly.
3. To remove the back from the base, use a screwdriver pressing outward on the black tab in the metal receivers on both sides of the chair back and lift the back from the base of the chair (2).
4. Connect the Headrest and Lumbar cable plugs (3). Headrest-only models feature one less set of cables.

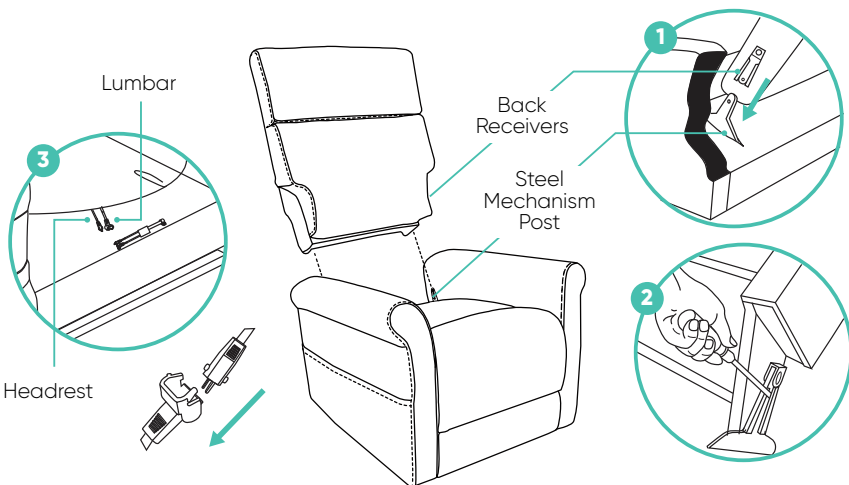

# Assembly

## Attaching the Wings to the Back

### Follow the steps below:

1. Slide the metal inserts on the chair's wings into the metal sleeves on the side of the chair back.
2. Slide the wings down until they are completely set on the back's metal sleeves.

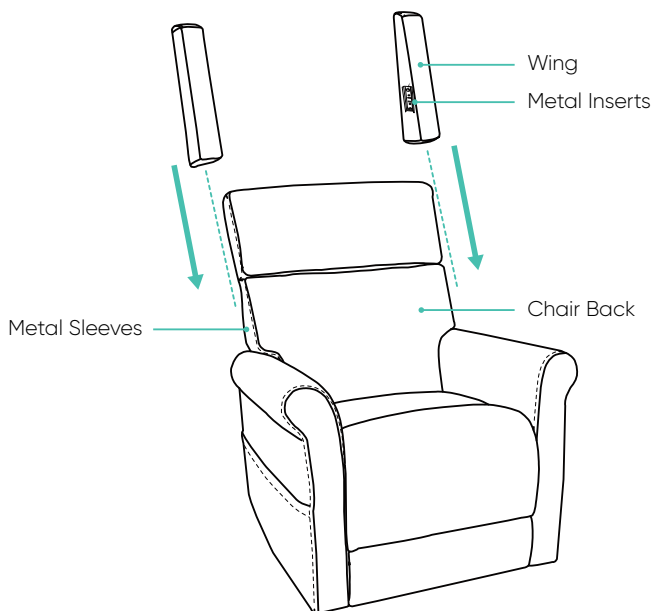

# Operation

## Handset (Dual Motor Zero Gravity)

### Donatello Plus KA554\_PL

**1. Memory Button** Allows user to preset their favourite seating position

**2. Headrest** Adjusts the headrest to help alleviate neck muscle strain, providing optimal support while reading or watching TV

**3. Lumbar Support** Adjusts the inbuilt lumbar cushion to provide tailored lower back support

**4. Raise:** Raises & tilts the chair forwards to assist users with standing

**5.Adjust:** Adjusts legrest to achieve a comfortable seated position

**5. Backrest :** Adjusts the backrest to provide postural support whatever the activity

**6. Legrest :** Retracts legrest to achieve a comfortable seated position

**7. Tilt:** Allows user to enjoy tilt-in-space or zero-gravity positioning and improves pressure redistribution

**8. Set Up Memory Function:** To setup memory function, adjust the chair position as the user desires, then press and hold the two tilt buttons together for 4 to 5 seconds, and press the "M" button until you hear a beep sound from the control box, to indicate that setup is complete.

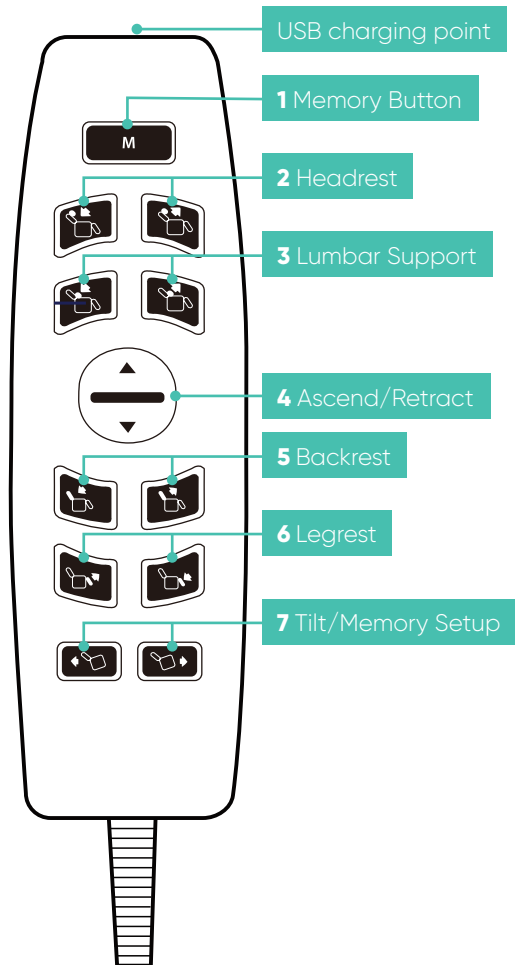



# Operation

## Handset (Dual Motor)

With Headrest, Lumbar & Air Massage System

### Carrington KA558

**1. Headrest** Adjusts the headrest to help alleviate neck muscle strain, providing optimal support while reading or watching TV

**2. Lumbar Support** Adjusts the inbuilt lumbar cushion to provide tailored lower back support

**3. Raise:** Raises and tilts the chair forward to assist users with standing

**4. Air Massage:** There are only two levels of massage (green or orange colour indications when massage function is active), unlit when massage function is not in use

**5. ALL Close :** Lowers the chair from a raised position and lifts the legrest once chair is flat on the floor.

**6. Backrest :** Adjusts the backrest to provide postural support whatever the activity

**7. Footrest :** Adjusts footrest to achieve a comfortable seated position

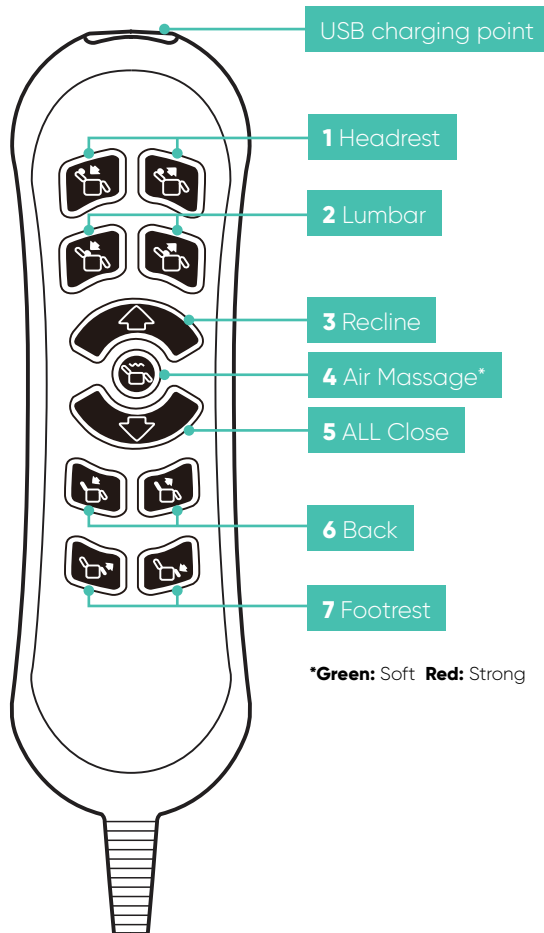

\*Green: Soft Red: Strong

#### These controllers are for models:

- Picasso (KA551)
- Leonardo (KA552)
- Michelangelo (KA553, KA556)
- Donatello (KA554-TB, KA554-LS, KA554-SB)
- Donatello (KA555-SB, KA555-LS, KA555LSC)

# Operation

## Handset (3 Motor)

### Kahlo KA557

**1. Headrest** Adjusts the headrest to help alleviate neck muscle strain, providing optimal support while reading or watching TV

**2. Lift / Legrest Raise:** Provides lift and tilt function - including raising the legrest when button held

**3. All Close / Legrest Close:** Lowers the chair from a raised position and lifts the legrest once chair is flat on the floor - and closes the legrest function

**4. Backrest :** Adjusts the backrest to provide postural support whatever the activity

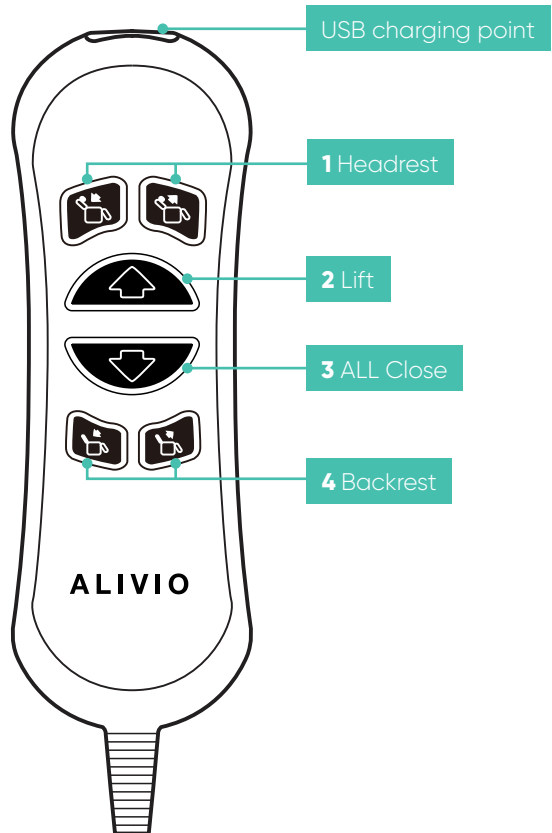

# Operation

## Handset

**1. Headrest** Adjusts the headrest to help alleviate neck muscle strain, providing optimal support while reading or watching TV

**2. Lumbar Support** Adjusts the inbuilt lumbar cushion to provide tailored lower back support

**3. Recline:** Used to raise the chair when requiring standing assistance

**4. ALL Close :** Lowers the chair from a raised position and lifts the legrest once chair is flat on the floor.

**5. Backrest :** Adjusts the backrest to provide postural support whatever the activity

**6. Footrest :** Adjusts footrest to achieve a comfortable seated position

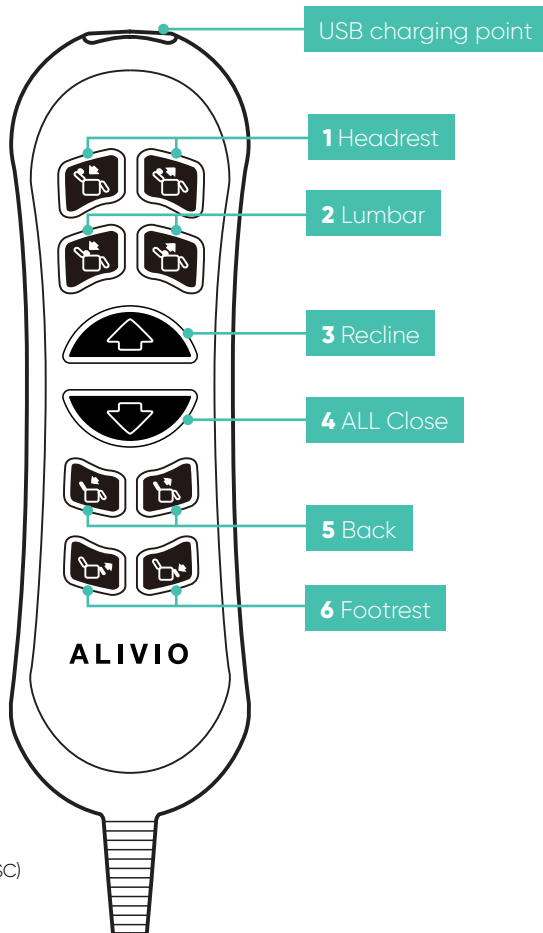

**These controllers are for models:**

- Picasso (KA551)
- Leonardo (KA552)
- Michelangelo (KA553)
- Michelangelo Petite (KA556)
- Donatello (KA554-SB, KA554-TB, KA554-LS, KAS554LSC)
- Donatello Petite (KA555-SB, KA555-LS, KA555LSC)
- Kahlo (KA557)

# Operation

## Wireless Phone Charger

1. Place phone on wireless pad and phone will start to charge automatically. (if the phone is a wireless charging model)
2. Will not work if phone has a magnetic cover on it.
3. Will not interfere with receiving a call if using Bluetooth headset/buds whilst on the charging pad.
4. Alternatively phone can be charged using the USB-A connector at the end of the handset with an appropriate charging cable.
5. Charging symbol will show on the battery symbol of the phone when charging is in process, same as if using a standard wall plug charger.

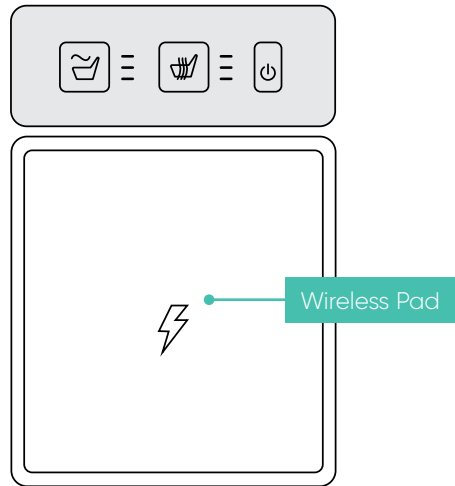

**The wireless phone charger is compliant with the following international standards.**

EN 55011:2016+A2:2021

EN 61000-3-3: 2013+ A1:2019 + A2:2021

EN IEC 61000-3-2: 2019+A1:2021

EN IEC 61000-6-1: 2019

## Maintenance

### Installation of Back-Up Batteries

2 - 9 Volt back-up batteries will lift the chair from the reclined position to the seating position one cycle in case of a power failure. If a power failure occurs and the chair is cycled, the 2-9 Volt batteries will need to be replaced.

1. Remove the sliding door on the side of the transformer to locate the 2 - 9 Volt batteries.
2. Pull out the 2- 9 Volt batteries and replace with new batteries.
3. Replace door on the transformer.
4. Batteries not included.

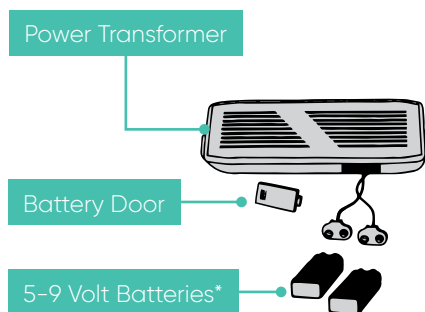

\*Batteries not included.

# Maintenance

## Lithium Ion Battery Back-Up System

If your chair is equipped with an external transformer with a lithium-ion battery pack, your chair may be operated without being plugged into an electrical outlet for up to 48 hours.

### Follow these steps to replace the lithium-ion battery pack batteries:

1. Unplug the external transformer power cord from electrical outlet
2. Position the external transformer with the lithium-ion battery facing upward (A).
3. Gently bump with your hand the end of the lithium-ion battery pack to dislodge it from external transformer.
4. Slide the lithium-ion battery until it stops and then lift the lithium-ion battery on top of the external transformer.
5. Place the new lithium-ion battery on top of the external transformer with securement grooves toward the external transformer (B).
6. Slide the new lithium-ion battery onto the external transformer until it clicks into place sleeves.

**NOTE:** Remove the lithium-ion battery from the battery pack when your chair isn't being used for an extended period of time. The chair will draw power from the battery even when it is not in use.

**Please see page 3 for Safety Precautions**

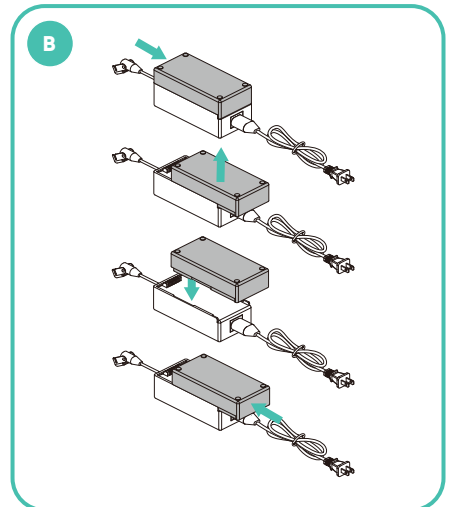
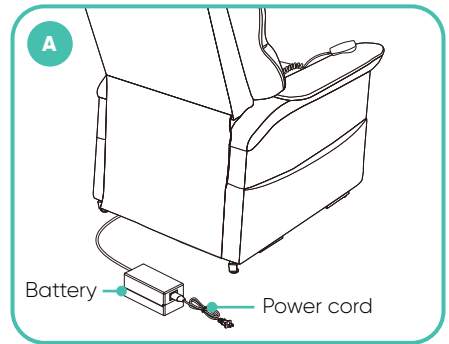

# Troubleshooting

Problem	Possible Factors	Solutions
<b>All Faults</b>	Power and cabling	Check power is available at the wall socket. Check cables for any signs of damage. Look for loose or incorrect connections.
<b>The chair doesn't lift or recline</b>	The transformer may not be connected well	Check the power supply has been correctly connected to the socket and confirm the wire from chair to transformer is firmly connected
<b>The headrest or lumbar doesn't work</b>	The headrest or lumbar motor may not be connected well	Check the headrest and lumbar motor has been correctly connected to the socket
<b>The headrest and lumbar work oppositely</b>	The headrest and lumbar motor plug	Check the headrest and lumbar motor has been correctly connected to the socket
<b>The handset doesn't work</b>	The handset may not be connected well	Check the handset cord has been correctly connected to the socket

## Cleaning and Maintenance

The Alivio Lift Chair should be cleaned regularly with a damp cloth and mild soapy solution or approved cleaner on heavily stained areas. K Care recommend application of a fabric protector such as K Care fabric armour. Treat stains promptly to prevent permanent staining on upholstery.

The handset is not fully water proof - for cleaning it can be wiped over with a damp cloth. Do not submerge in liquid.

### Motor

The motors are maintenance free. They are protected by thermal overloads and will stop automatically if operated excessively. Do not attempt to clean the motors or any electrical parts with any liquid. If the motors stop after over-use, wait until the motors have cooled before further use.



# Warranty Against Defects

Product	Warranty Period
<b>Steel Frame:</b>	5 years
<b>Motor</b>	5 years
<b>Electronics:</b>	2 years
<b>Handset and Cable:</b>	2 years
<b>Scissor Mechanism:</b>	3 years
<b>Steel Lift Mechanism:</b>	3 years
<b>Fabric and Foam:</b>	2 years

### **Five-Year Limited Warranty**

For five (5) years from the date of purchase, K Care will repair or replace at our option to the original purchaser any of the following parts found upon examination by an authorised representative of K Care to be defective in material and/or workmanship:

- Steel Frame
- Motor

**NOTE:** K Care reserves the right to replace only the part of the steel lift mechanism that may be defective. K Care provides parts only under warranty. Your K Care Dealer is responsible for labour and service. Please contact your K Care Dealer for information about these services and for any applicable charges.

### **Three-Year Limited Warranty**

- Scissor Mechanism
- Steel Lift Mechanism

### **Two-Year Fabric and FOAM Warranty**

K Care guarantees to replace any fabric that is found to be faulty as a result of manufacturing defect and which has been used in accordance with our manufacturer performance ratings and care instructions.

An evaluation of fabric related issues must be conducted before confirmation

of warranty coverage can be verified. K Care recommends stain resistant treatment before use.

### **Consumer Warranty Against Defects:**

K Care does not warrant against excessive or incorrect use, modification or any situation that could not be deemed as fair wear and tear. This is a back to base warranty and does not cover freight costs pertaining to the return of any items under warranty. K Care acknowledges and conforms to all ACCC guidelines around consumer rights.

K Care will not warrant the safety and or correct functioning of products where any original components have been changed or modified by non-K Care approved and trained service and maintenance staff or external providers.

Furthermore, safety is not guaranteed where components have been replaced with non-original K Care approved parts. If any faults are detected upon receipt of this product please contact K Care. Any faults that are detected during normal use should be reported to K Care immediately to determine if warranty conditions apply and if so, the necessary repair or replacement work to be completed.

1. K Care Healthcare Equipment provides consumers with the following warranty in relation to this Product, in addition to complying with the requirements of any relevant legislation, including the Competition and Consumer Act 2010 (Cth) in Australia and the Consumer Guarantees Act 1993 in New Zealand (the Acts), except where a New Zealand consumer acquires the Product for the purposes of a business.
2. In this warranty, we have used the following definitions:
  - (a) Form means a warranty claim form issued by K Care Healthcare Equipment in respect of Products.
  - (b) K Care Healthcare Equipment or our means K Care Healthcare Equipment,
  - (c) Products means the goods manufactured by K Care Healthcare Equipment (including products manufactured by its contract manufacturers) set out in the table above;
  - (d) Material means a material or component used by K Care Healthcare Equipment in the manufacture of the Products;
  - (e) Retailer means the authorised dealer of Products from whom the Product was purchased;
  - (f) Warranty Period means the warranty period set out in the table above, commencing from the date of purchase of the relevant Product. If the Product or part (as the case may be) is repaired or replaced, there will be no extension to the original warranty period; and
  - (g) Workmanship means the handling, assembly and manufacturing processes performed by or on behalf of K Care Healthcare Equipment in order to manufacture the Products.
3. K Care Healthcare Equipment warrants that for the duration of the Warranty Period, all Products will be free of faults arising from defects in Workmanship or Materials, on the terms and conditions set out in this warranty.
4. K Care Healthcare Equipment undertakes that if during the Warranty Period any Product, or any part of a Product, has failed to operate correctly due to faulty Workmanship or defective Material, it will repair or replace the Product or part (as the case may be) free of charge (excluding freight fees if applicable) provided that the following procedure is met:
  - (a) The consumer must contact the Retailer or K Care Healthcare Equipment upon becoming aware of any defect to a Product. The consumer will then be provided with a Form, which must be completed by the consumer and returned to K Care Healthcare Equipment together with satisfactory proof of purchase.
    - (b) K Care Healthcare Equipment will review the Form to determine whether there is a defect, and if so K Care Healthcare Equipment agrees to (at its option) repair, replace or supply equivalent goods, or pay the cost of any of those remedies to the consumer.
    - (c) If K Care Healthcare Equipment requests the return of the applicable Product or part, the consumer will be responsible for the collection and freight costs of returning that Product or part to K Care Healthcare Equipment.
    - (d) The consumer acknowledges that it is also responsible for the freight costs to deliver any new Product or replacement part to it.
5. To the extent that the supply of Products is a supply to a consumer within the meaning of the applicable Act, the consumer is entitled to consumer guarantees which K Care Healthcare Equipment does not exclude, restrict or modify. In all other respects, and to the extent permitted by law, K Care Healthcare Equipment:
  - (a) Limits its liability for any non-excludable condition or warranty to rectifying any defect at its option, as set out in paragraph 4 (b); and
  - (b) Excludes liability (whether express or implied) of any nature whatsoever for any consequential loss, damage or injury arising as a result of any fault in the Products.
6. This warranty does not extend to damage to Products which occurs during transit or transportation, or which is caused by any abuse, accident or improper installation, connection, use, adjustment or repair or use of goods otherwise than in accordance with instructions issued by K Care Healthcare Equipment.
7. The warranty on Products is waived if any addition or attachment to the Products do not have K Care Healthcare Equipment's approval or are not sold as K Care Healthcare Equipment products. The Products are designed to perform specific tasks under established test loads and unauthorised attachments may produce stresses for which the design is not appropriate.
8. The following applies to consumers who purchased a relevant Product in Australia: Our goods come with guarantees that cannot be excluded under the Australian Consumer Law. You are entitled to a replacement or refund for a major failure and compensation for any other reasonably foreseeable loss or damage. You are also entitled to have the goods repaired or replaced if the goods fail to be of acceptable quality and the failure does not amount to a major failure.

# Improving your life everyday™

## **At Your Service**

Sales, administration  
and general enquiries

National 1300 783 783

Your Customer Service Team  
customerservice@K Care.com.au

**K Care.com.au**

All information is considered to be true and correct at the date of publication. Changes in circumstances after the time of publication may impact on the accuracy of the information.

