



## LIFT CHAIR - USER MANUAL

## CONTENTS:

1. Introduction
2. Users' Precautions
3. Safety
4. Features
5. Specification
6. Installation
7. Usage- Remote Control
8. Product Repair
9. Maintenance/ Product Care
10. Product Storage
11. Warranty

*No part of this user manual may be copied, distributed, reproduced, duplicated, scanned or stored whether in whole or part in any form or by any means without the expressed written consent from the officers of Independent Living Specialists Pty Ltd. Independent Living Specialists does not accept responsibility for any changes, errors or omissions. All information is subject to change without prior notice and products may vary from that of the actual images depicted.*

## 1. INTRODUCTION

This is an electrical lift chair designed to help people rise easily from the chair.

Before you start using the chair, please read our instruction manual carefully and please follow the safety procedures recommended.

Please keep this manual safely for future reference.

## 2. USERS PRECAUTION

If you have any of the following medical problems, please consult a doctor before use:

- If you are suffering from heart disease
- If you wear a pacemaker
- If you are suffering from tumors
- If you have spinal disorder
- If you have sever back pain
- If you suffer from any injuries
- If you are under medical care or medical rest
- If you are recovering from surgery
- If you are physically or mentally unwell
- If you suffer from high fever
- If you are taking prescription drugs
- If you (women) are pregnant or menstruating

### 3. SAFETY

Before using the lift chair, please follow the basic safety rules given below to avoid electrical shocks, or any physical and material damages.

- The chair must be assembled correctly according to the Assembly instruction enclosed. The manufacturers of the chair, their agents and distributors are not liable for any damages caused by improper assembly of the chair.
- The chair must be assembled by using all the parts and screws provided.
- The chair must be placed on the flat floor level.
- Do not use this chair in humid or dusty environment, as it may cause electrical shock or machine trouble. The chair must be in a dry room.
- Do not use this chair in room temperature higher than 40°C.
- Do not expose this chair to direct sunlight, stoves, heaters and any other heating appliances.
- Do not use the chair outdoors.
- When the chair is not in use, disconnect the power plug from the main supply to avoid overheating.
- Do not increase the room temperature suddenly. You must increase the temperature gradually. If the chair is moved from a cold to a warmer place, do not use the chair for at least a couple of hours.
- Do not use this chair in combination with other therapeutic or beauty equipments such as massage mat, slimming machine or electric blanket.
- Do not use the chair if you are not well.
- Stop using the chair if you notice any pain or discomfort during the operation of the chair.
- Do not allow children or pets to play on or around the chair. Children must be supervised by an adult when using the massage chair. This chair is not for children.
- Do not place any heavy object on the armrest, footrest or backrest.
- Do not jump or play on the chair.
- Do not rock the chair, it is not a rocking chair.
- Do not sleep on the chair during operation.
- Do not use the chair when your body is wet or damp.
- Before operating the chair, check that the local voltage corresponds with the specifications indicated for the chair.
- Electrical connection must be made in accordance with local regulation.
- Do not connect or disconnect the power plug to/from the electrical outlet roughly.

- When disconnecting the plug, pull it out by holding the plug and not by the cord.
- Do not connect or disconnect the plug from the electrical outlet with wet hands. It may result in electrical shock or machine trouble.
- To avoid electrical shock, the power plug and cord must always be dry. Never wet the power plug and cord or touch them with wet hands.
- Although the massage system will be stopped automatically by the Auto-Timer function, you must always turn off the system by pushing down the Power On/Off button after operation.
- Do not place the power cord under any objects including the chair as it may damage the cord and result in fire or electrical shock.
- Do not let the power cord hang down from the chair.
- Do not operate the chair if the power cord or plug is damaged. Do not try to change the damaged plug or cord by yourself. Always contact a qualified technician or the After Sales Service for inspection and repair.
- Do not operate the chair if the electrical outlet is excessively loose or damage. Always contact a qualified technician for inspection and repair.
- Do not touch the surface of the plug immediately after use, as it can be very hot.
- Do not operate the remote control with wet hands or with sharp or hard objects
- Do not drop the remote control.
- Do not sit, step or place heavy objects on the remote control.
- Do not operate the remote control with excessive force.
- Do not sit or lie on your side or stomach during operation of the chair. You must always sit or lie upright and on your back.
- Do not put your fingers or any object between the seat and footrest.
- Before cleaning or repairing the chair, make sure the main switch is turned off and the power plug disconnected from the electrical outlet.
- Do not wash the chair with water.
- Do not use the chair if the upholstery or any part of the chair is damaged.
- This chair can bear a maximum weights of 150kg. Person (s) above this weight should not sit on this chair as it may damage the chair.
- Do not remove the back cover from the chair. Touching the inside mechanisms of the chair may result in electric shock.
- Do not touch, remove, repair or tamper with the inside mechanism of the chair. This may result in fire or electric shock.
- This chair must be used in accordance with the instruction provided.

- All repair must be done by a qualified technician or the After Sales Service. Do not attempt to repair anything yourself.
- This chair is intended solely for relaxation use. Any other use (professional) is prohibited and is not guaranteed.
- The manufacturer of this chair, their agents and distributors are not liable for any damages caused to person(s), object(s), animal(s) or property(s) resulting from improper and misuse of the chair.
- Keep this Instruction Book for future reference.

### **IMPORTANT NOTE:**

Should you use the chair in a cold room, do not increase the room temperature abruptly. It is recommended that you increase temperature gradually to a normal level. In the event that the chair is stored in a cold place and is being brought into a warm place, it is advisable to use it one hour later. This is because its performance may not be at its optimum level as it may have dew on the mechanical parts. Machine trouble may be resulted when a cold machine is being used in a warm room suddenly.

### **WARNING:**

#### **Stop using the chair:**

- If water is spilt on the chair. Continuous usage may result in electric shocks.
- If the upholstery or any part of the chair is torn or damaged.
- If the chair has malfunction during operation.
- If there is a power failure. Injury may occur if the power is restored unexpectedly.
- If there is a thunderstorm & lightning.

• If you suffer from abnormal or severe pain during the operation of the chair  
In any of the above events switch OFF the power immediately and disconnect the power cord from the power outlet.

### **Note:**

- Check for tears in the Upholstery Cloth regularly.
- Check all wires, plug and the remote control regularly for any damage.

## **4. FEATURES**

- Comfortable design
- Easy to use
- Infinite recline position
- Infinite lift position
- A complete and easy to use remote control
- Backup system

## 5. SPECIFICATION

### Weight

- The weight of the chair is 62 kg.
- The maximum weight the chair can bear is 150KGS

### Power

- Voltage: 240V
- Frequency: 50Hz
- Power: 50W

## 6. INSTALLATION

### Assembly

The chair is packed in semi knock down form consisting of the back, and the seat.

- Assemble the chair according to the instruction given in the Assembly instruction.
- Do not substitute the missing parts with your own. If anything is missing contact the shop and ask for replacement.
- Do not assemble the chair with damaged parts.
- Do not assemble the chair if the upholstery or any of the parts of the chair are damaged.

**A/ CONNECT THE BACKREST OF THE CHAIR TO THE SEAT OF THE CHAIR.**

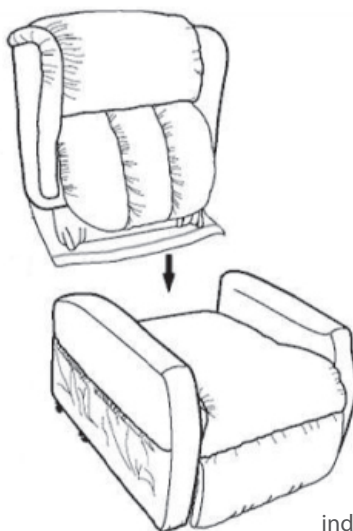

indicative image only



## B/ ADAPTOR CONNECTION AND FITTING

### Step 1

Take out the adaptor from the polybag. See Diagram 1 below:

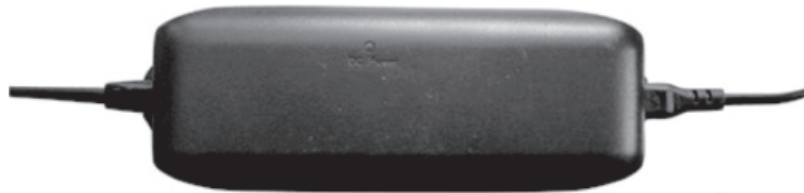

indicative image only

### Step 2

Remove the remote control from the polybag:



indicative image only

Connect the wire from remote control to the wire from the actuator.

## PLACING OF THE CHAIR

ROYALE



### CAUTION:

1. Make sure there is no obstruction behind or in front/ or above the Chair for a safe recline and lift during operation.

No finger or object should be placed between the chair and the footrest.

- Once the chair is assembled as per assembly instruction, place the chair in a dry room, with sufficient space in front and behind it.
- Make sure there is an allowance of more than 50 cm behind the chair and more than 30cm in front of the chair.
- Place the chair on a flat and smooth floor. Do not place the chair on uneven floor.
- As per safety instruction, the room must not be too hot (below 40°C) nor humid, nor dusty or it may cause malfunction and electric shock.

## INSTALLATION OF CASTORS

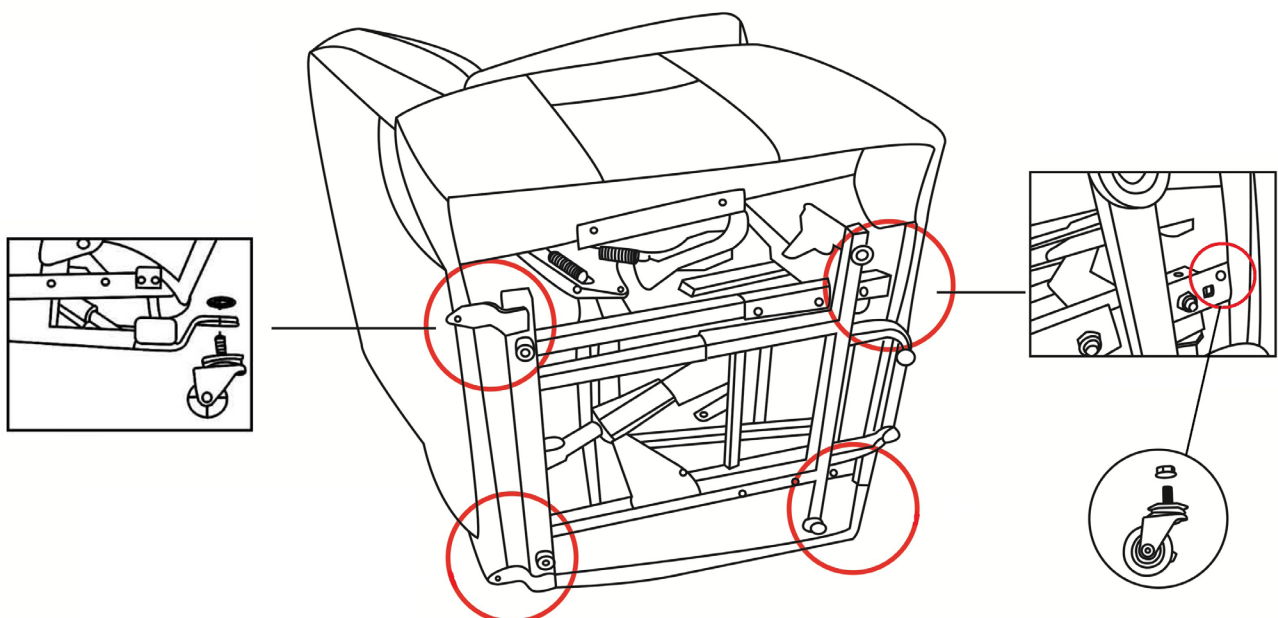

## 7. USAGE

Before operating the chairs, make sure that there is no obstruction behind, in front or above the chair. There must be sufficient space around the chair to make sure that the chair moves smoothly through all positions.

During the operation of the chair, make sure that you do not place your fingers hand or any object between the chair and the footrest. Be very careful to keep the space between the chair and the footrest totally clear.

The remote control is used for the operation of all the functions of the chair. The functions on the remote control are activated by pressing the buttons gently.



indicative image only

## LIFE FUNCTION

- Press the top 1 white button with arrow pointing up to lift the chair. Continue pressing the button until you have reached the desired height. (The chair will stop lifting automatically once it has reached the maximum height)
- Release the button and the chair will stop lifting.



indicative image only

### SIT FUNCTION (FROM LIFT POSITION)

- Press the bottom white button with arrow pointing down to sit position. Continue pressing the button until you have reached the desired position.
- Release the button and the chair will stop moving down.



indicative image only

### RECLINE FUNCTION (FROM SIT POSITION)

- Press the bottom white button with arrow pointing down and the backrest of the chair will recline. Continue pressing the button until you have reached the desired position.
- Release the button and the chair will stop moving.

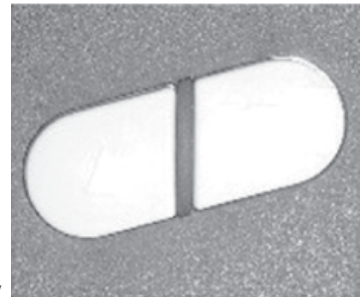

indicative image only

### SIT FUNCTION (FROM RECLINE POSITION)

- Press the top white button with arrow pointing up and the backrest of the chair move upward. Continue pressing the button until you have reached the desired position.
- Release the button and the backrest will stop moving.



indicative image only

## 8. PRODUCT REPAIR

Before repairing, ensure that the power is turned off and the power plug is removed from the electrical outlet.

- Do not attempt to repair any parts of the chair by yourself.
- Do not change the power plug by yourself.
- Do not disassemble the chair, remove any inside mechanism by yourself.
- The chair must be serviced or repaired by a professional.
- Contact a qualified technician or the After Sales Service for all servicing and repairing

## 9. PRODUCT REPAIR

Before cleaning ensure that the power is turned off and the power plug is removed from the electrical outlet.

- Do not change the power plug by yourself.
- Do not disassemble the chair, remove any inside mechanism by yourself.
- The chair must be serviced or repaired by a professional.
- Contact a qualified technician or the After Sales Service for all servicing and repairing

### A/ THE CHAIR

- Do not remove the upholstery for cleaning. Touching the inside mechanism of the chair may result in electrical shock.
- Never use water to wash or clean any part of the chair.
- The upholstery of the chair must be cleaned with dry cloth only.
- Do not use any cleaning agents or thinners or bleaching agents to clean the upholstery.
- Do not wash the upholstery.
- Ironing of upholstery is strictly prohibited.
- The handles and the rest of the chair must be cleaned with dry cloth.

### B/ THE REMOTE CONTROL

- The remote control is cleaned only with dry cloth. Never use water or wet cloth which will result in machine trouble.

## 10. PRODUCT STORAGE

Before storing the chair make sure that the main switch is turned off and the power plug is removed from the electrical outlet.

- Wipe the dust and dirt off. Keep the chair clean and away from places of high humidity.
- If the chair is not in use for a long period of time, cover it with a piece of clean cloth to protect it from dust. Store in dry room.
- Do not store the chair under direct sunlight or in places of high temperatures. This may result in fading of fabric colour.

## 11. WARRANTY OUTLINED

ROYALE MEDICAL will repair or replace at our option to the original purchaser any of the following found upon examination by an authorised representative of ROYALE MEDICAL to be defective in material and /or workmanship.

1. Electrics including Transformer, Hand control, Motor, and all Cables - 2 Years
2. Steel Lift/Recline Mechanism - 2 Years
3. Timber Frame (Structural & Workmanship) 2 Years

### NOT COVERED UNDER WARRANTY

ROYALE MEDICAL does not cover anything which is deemed to be damaged through misuse or accident. The fabric is classed as a wear item and under normal wear and tear may need to be replaced. Therefore the fabric is not covered under warranty.

### NOTE

ROYALE MEDICAL will provide parts only under warranty.

Your ROYALE MEDICAL dealer is responsible for labour and freight charges.

Please contact your ROYALE MEDICAL dealer for information about this.